



**MAINTENANCE AND OPERATING INSTRUCTIONS
MODEL 36-009-1
"NOBRUSH" PERMANENT MAGNET ALTERNATOR**

GEORATOR Corporation
9617 Center Street
Manassas, Virginia 20110
USA
800-523-9938, 703-368-2101, fax 703-368-1078
WWW.Georator.com



SPECIFICATION
GEORATOR CORPORATION
 MANASSAS, VIRGINIA 20110

Model No. 36-009-1
Type 20-A Alternator

1.0 OUTPUT:

- 1.1 Rating: 2.5 KVA, 100% P.F., I Phase, 400 Hz, 115V (Nom.)
1714 RPM
- 1.2 Output Voltage, No Load: 124V +-1V
- 1.3 Current Rating: 21.8 Amps
- 1.4 Insulation: Class B
- 1.5 Max. Ambient Temperature: 50 Degrees C
- 1.6 Duty: Continuous
- 1.7 Dielectric Strength, Winding To Frame: 1500V For I Minute

2.0 ROTOR BALANCE: Within 0.001

3.0 BEARINGS: Shielded Life Time Lubricated

4.0 FINISH:

- 4.1 Primer: Iridite
- 4.2 Paint: Silver-Blue Enamel
- 4.3 Fasteners: Zinc-Plated

5.0 APPROX. WEIGHT:

- 5.1 Net: 104 Lbs.
- 5.2 Shipping: 140 Lbs.

Revision Letter	Date	Revision Description
ENGINEER		M.T.E.
APPROVED BY		April 20, 1998

GEORATOR CORPORATION

Manassas, Virginia

MAINTENANCE AND OPERATING INSTRUCTIONS

MODEL 36-009-1

“NOBRUSH” PERMANENT MAGNET ALTERNATOR

NOTE

Some instructions are general in nature. Some particular models may vary in size and precise locations for components. However, we believe that the user will be able to make those adjustment mentally. If you are at all concerned, please feel free to contact Georator Corporation with any questions you may have.

GENERAL

The “NoBrush” Alternator utilizes a metal housing enclosing the generator components. In most models, this housing is an aluminum casting. In a few militarized models, it is a steel housing. The generator rotor is mounted upon a shaft, which rotates on ball bearing.

The internal construction of the generator resembles very closely that of a three phase, squirrel cage, induction motor. The maintenance attention required will be the same as would be required for a three phase motor, operating under similar conditions.

Generally attention will be required only if the unit has accidentally been immersed in water, or has been exposed for long periods to very dusty atmospheres, especially where fibrous dust exists. In such cases it will be desirable to disassemble the unit and clean the winding. The other condition for which disassembly is required, will be replacement of a defective bearing. The procedure for disassembly of the unit and replacement of the bearings is given on page 3.

In most models, shielded lubricated-for-life bearings are utilized. These will not normally need lubrication, nor other attention of any sort.

The alternator will not be adversely affected by dead short circuit applied across its terminals. A prolonged short circuit, however, can overheat the unit and can also result in damaging the associated wiring and equipment. Normal overload protection should therefore, be provided.

OUTPUT CONNECTIONS

A terminal box at one side of the unit has the alternator output terminals. The wiring diagram is supplied with each unit.

NOTE: DO NOT APPLY EITHER AC OR DC TO ANY OF THE WINDINGS OF THE GENERATOR.

MAINTENANCE OF ALTERNATOR

CLEANING

It is most important that accumulations of oil, water, dirt, and dust are not permitted to cover the machine, enter it, or block ventilation. Remove any such accumulations from the machine and surrounding operating area.

Wipe the exterior of the machine to keep it clean. When necessary, use a suitable solvent to remove dirt accumulations from the machine surface.

Electrical machines should be protected from and kept free of acids, alkalines, chemical compounds and gas fumes that may cause insulation deterioration.

CLEAN WINDINGS

Accumulations of any foreign materials should be kept off the windings. Failure to keep the windings clean may result in short circuits, grounding of insulated surfaces, and in increased temperature rise.

The frequency of cleaning windings will have to be determined by operating conditions. However, it is a good policy to clean the windings at least once a year. Greasy or oily deposits may be wiped off with a lint free cloth dipped in a suitable solvent. Take care not to leave solvent deposits on the windings. Light accumulations of nonconductive dust

may be removed by compressed air. Use a pressure range of 40 to 60 psi. Do not blow directly into the windings. When dirt and dust accumulations are heavy or of a highly conductive nature, it is best to use an especially built vacuum cleaner to clean the machine. Follow the cleaner instructions carefully.

SOLVENTS

When the parts of a motor and generator need cleaning, use a suitable petroleum solvent such as kerosene, petroleum spirits or standard solvent. Care must be taken to utilize solvents in accordance with the solvent manufacturer's instructions. Protection in accordance with local laws regarding fire hazards must be provided. Gasoline containing lead compounds should not be used because of their toxic nature. Light petroleum solvents may be more effective but must be free of corrosive action and must be followed up with flushing oil.

BEARINGS

Bearings Life is estimated at more than 10,000 operating hours for normal operating conditions. Bearing replacement is required only when the bearings become noisy. This requires the disassembly of the unit.

TO DISASSEMBLE ALTERNATOR

In the event the disassembly of the alternator becomes necessary for replacement of bearings, etc., the following step-by-step instructions are recommended.

1. Remove four bolts, Item 1, from each end bell.
2. Set generator upright on a shaft end. Use wood or hard rubber block to protect the shaft.
3. Lift generator to a height of 4 to 6 inches and drop on shaft. Be careful to steady the shaft assembly, Item 5, not letting it fall to the side. This shock is necessary to overcome the attraction due to the magnetism of the rotor.
4. Remove the end bell, Item 4, and lift out shaft assembly, Item 5. Caution must be exercised here to prevent the rotor from damaging the winding. Wrap rotor with paper and keep away from tools and all other magnetic material.
5. Remove other end bell (if unit has 2 end bells).
6. Bearings, Item 7, may be removed with a standard bearing puller.

To replace bearings, Item 7, press only on the inside race. Never remove a bearing that is not to be replaced with a new one.

TO REASSEMBLE ALTERNATOR

1. Replace end bell, Item 4, on housing.
2. Lay generator flat on side having end bell installed, on blocks, to allow for shaft extension clearance.
3. Remove any dirt or grit that may have adhered to the rotor. Lower shaft assembly, Item 5, gently into place with tapped end (For Eyebolt) of shaft up. Caution must be exercised here -- keep fingers clear of rotor while replacing it and prevent rotor from damaging the winding.
4. Put on other end bell, if applicable, and tighten four bolts, Item 1, alternately. Turn shaft by hand to check for ease of rotation. A light tap with a rubber mallet on bearing housing may relieve any binding.

ITEM NO.	QTY.	DESCRIPTION
1	1	FRAME
2	1	STATOR ASSY.
3	8	RETAINING WASHER
4	8	SCREW
5	1	SHAFT ASSY. (SHAFT, ROTOR, FAN)
6	2	BALL-BEARING
7	1	END BELL
8	1	SPRING WASHER
9	4	THRU BOLT
10	4	NUT
11	1	PLUG, END BELL
12	1	TERMINAL BOX
13	2	SCREW
14	2	FLATWASHER
15	1	COVER
16	4	SCREW
17	4	LOCKWASHER
18	1	NAME PLATE
19	4	SCREW
20	1	KEY
21	1	PLUG, TERMINAL BOX
22	4	LOCKWASHER

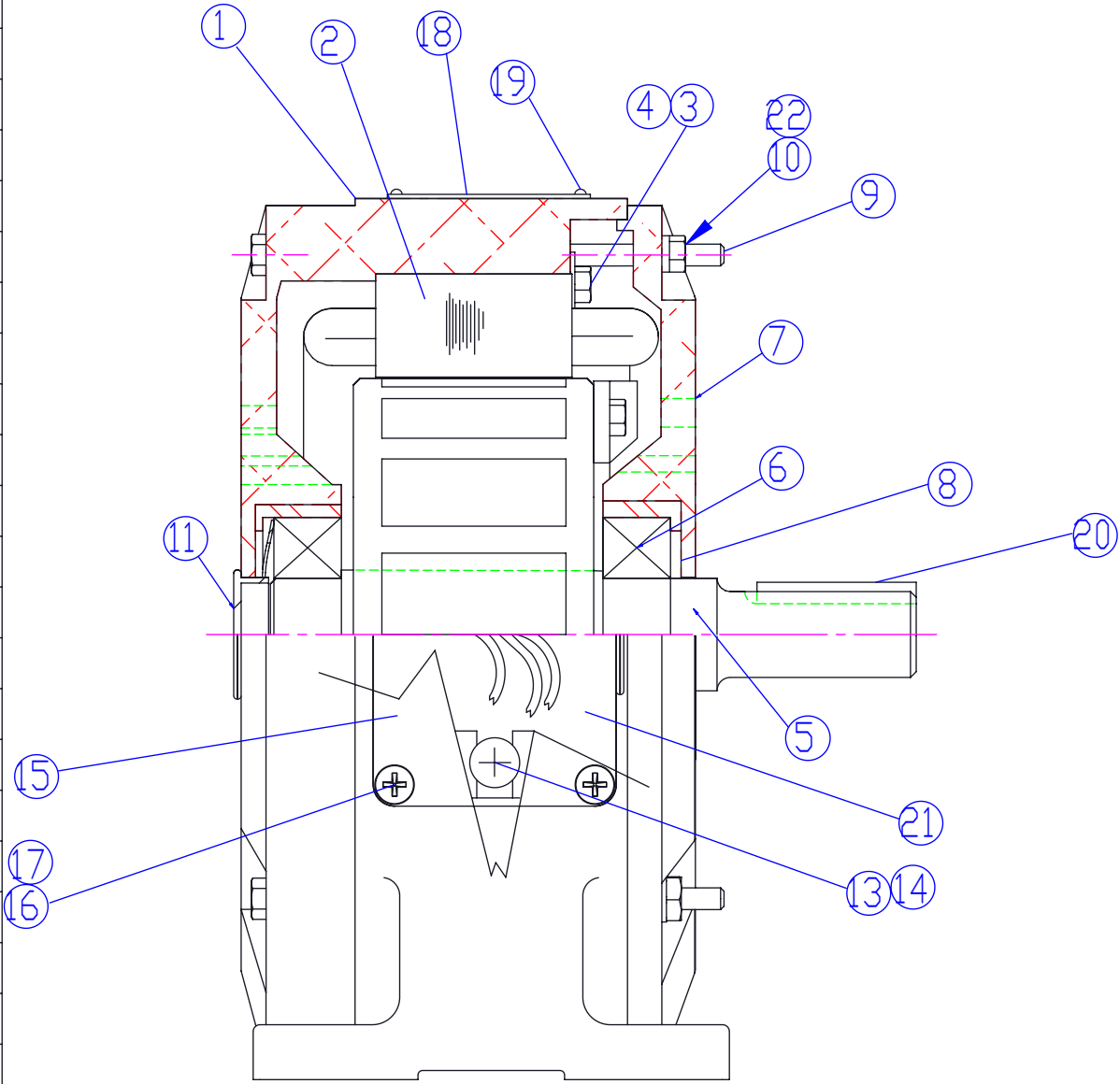

UNLESS OTHERWISE SPECIFIED TOLERANCES ARE IN INCHES		UNLESS OTHERWISE SPECIFIED DIMENSIONS ARE IN INCHES		 GEORATOR Corporation 3617 Center Street Manassas, VA 20110-5521, US Telephone (703)-368-2101 FAX (703) 368-1078	
DO NOT SCALE DRAWING		DATE: 9-16-65		NAME: ASSEMBLY DRAWING	
PLOT @: TO FIT		DRAWN: 22-004.DWG		SERIES 36	
This drawing and any print thereof is the property of Georator Corporation and is subject to return on request by this company. The information shown is confidential and the recipient by accepting this drawing agrees not to use any information contained therein in any manner which will be detrimental to Georator Corporation.		MATERIAL: SEE PARTS LIST		REV: A	
REV	DESCRIPTION	DATE	BY	SCALE	SHEET 1 OF 1

REV	DESCRIPTION	APP'VD	DATE
A	13.6 WAS 13.5 & 19.2 WAS 20.2		08/09/83
B	13.7 WAS 13.6 & 3.7 WAS 3.6		01/09/84
C	REDRAWN IN AUTOCAD	B.S.O.	04/03/02

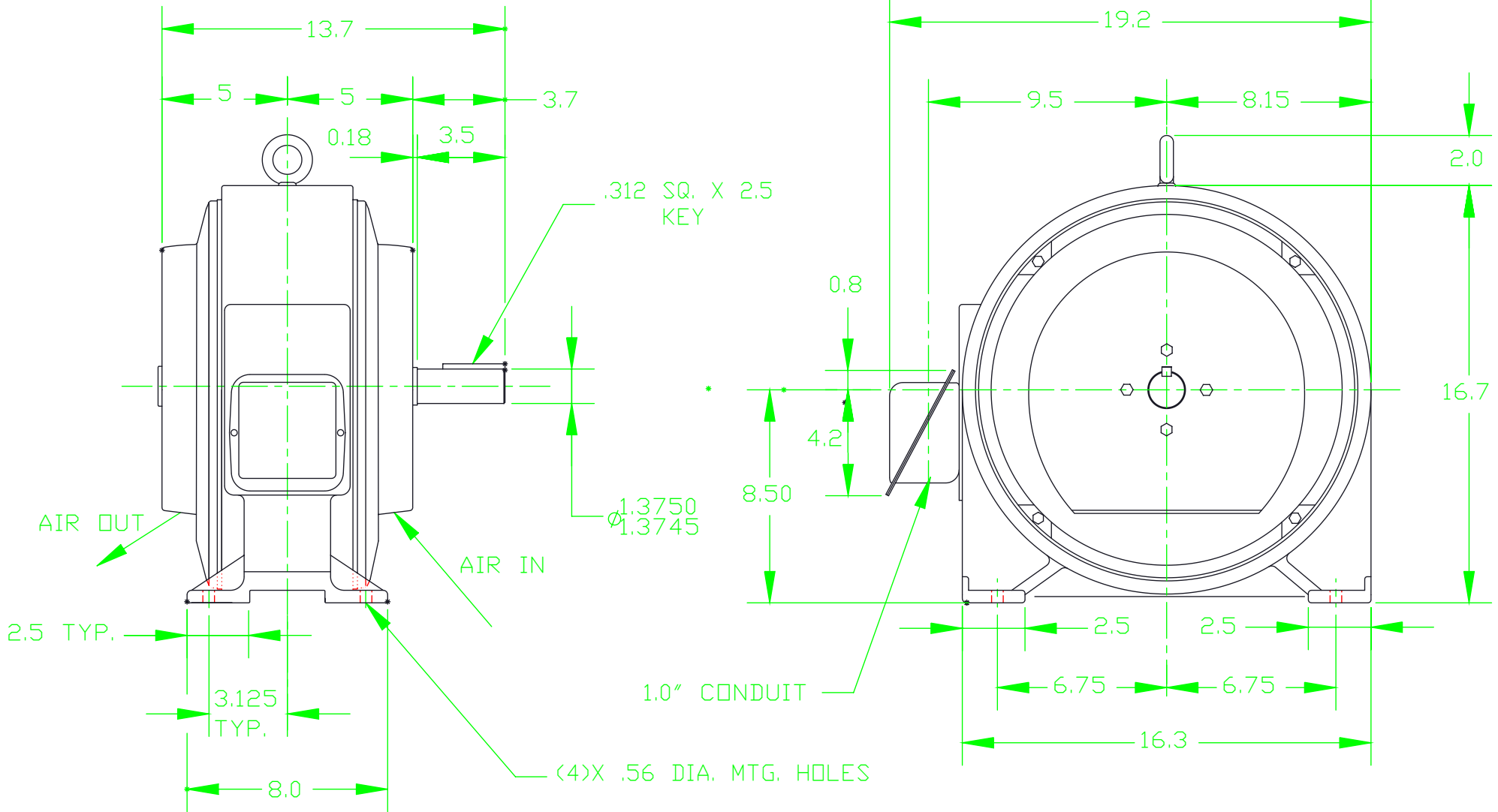

UNSPECIFIED TOLERANCES FRACTIONAL N/A DECIMAL		UNLESS OTHERWISE SPECIFIED DIMENSIONS ARE IN INCHES.		 GEORATOR Corporation 9617 Center Street Manassas, VA 20110-5521, USA Telephone (703)-368-2101 FAX (703) 368-1078	
.X ±0.1 ANGULAR ±0°30'		NEXT ASSY XXXXXXXXXX			
.XX ±0.03		DO NOT SCALE DRAWING		OUTLINE DRAWING SERIES 36 ALTERNATOR	
.XXX ±0.010		DATE 03/28/83			
PLOT @ FIT		DRAWN F.L.		MATERIAL	
This drawing and any part thereof is the property of GEORATOR CORPORATION, and is subject to return on request by this company. The information shown is confidential and the recipient by accepting this drawing agrees not to use any information contained thereon in any manner which will be detrimental to GEORATOR CORPORATION.		FILE: 23-979.DWG		FINISH	
		APP'D.		DWG. NO.	
		SCALE NONE		SHEET 1 OF 1	
				A 23-979	
				REV. C	

OUTPUT



1 PHASE

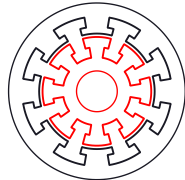

							GEORATOR Corporation	
				DATE	9-5-62		9617 Center Street Manassas, VA 20110-5521, USA	
				DRAWN	F.L.		Telephone (703)-368-2101 FAX (703) 368-1078	
				FILE:	25-113.DWG		NAME	
A	DRAWN ON CAD	4-24-08	F.M.	APP'D.		WIRING DIAGRAM, OUTPUT: 1 PHASE		
REV.	DESCRIPTION	DATE	BY	SCALE	NONE	SHEET 1 OF 1	DWG. NO. A 25-113	REV.