



**MAINTENANCE AND OPERATING INSTRUCTIONS  
MODEL 33-006-1 MOTOR-GENERATOR  
"NOBRUSH" PERMANENT MAGNET FREQUENCY  
CONVERTER  
VERTICAL TYPE**

GEORATOR Corporation  
9617 Center Street  
Manassas, Virginia 20110  
USA  
800-523-9938, 703-368-2101, fax 703-368-1078  
[WWW.Georator.com](http://WWW.Georator.com)



**GEORATOR CORPORATION**  
Manassas, Virginia

**MAINTENANCE AND OPERATING INSTRUCTIONS**  
Model 33-006-1 MOTOR-GENERATOR  
"NOBRUSH" FREQUENCY CONVERTER  
VERTICAL TYPE

**NOTE**

Some instructions are general in nature. Some particular models may vary in size and precise locations for components. However, we believe that the user will be able to make those adjustment mentally. If you are at all concerned, please feel free to contact Georator Corporation with any questions you may have.

**GENERAL**

The "NoBrush" vertical converter is a vertically mounted motor generator set used to convert 60 Hz frequency to 400 Hz frequency. The lower portion consists of the generator and the upper the motor. The generator and motor stators are mounted in cast aluminum housings held together at the center flange by four (4) bolts. The generator and motor rotors are mounted on a common shaft axially located by bearings in journals machined in the stator housings.

The drive motor is the induction type which means that it is very simple in construction and operation, and practically maintenance free. The rotor is the die cast aluminum squirrel cage type. The stator is wound for 208 Volt input operation.

The Georator Corporation "NoBrush" alternator is probably the most reliable, rugged and trouble free generator built. The rotor consists of permanent magnets integrally cast in aluminum with the hub and pole pieces providing the field. Brushes, slip rings, etc. and their associated maintenance problems are eliminated. The stator is the armature.

Since the field is permanent magnet (Alnico) the field flux is constant with no variation due to time or to temperature changes. Thus the generator output voltage is constant and cannot be easily changed.

The generator has internal protection against demagnetization from short circuit and will not be adversely affected by a short across its terminals for a short time duration.

**NOTE: DO NOT APPLY EITHER AC OR DC TO ANY OF THE  
WINDINGS OF THE GENERATOR.**

A voltage applied to the generator leads may cause the rotor magnets to demagnetize or damage

the stator.

The "NoBrush" generator is customarily operated without regulating equipment of any nature. The generator is wound to deliver, on open circuit, a higher than nominal voltage. On application of load there is a drop in voltage depending upon load power factor. For a constant load condition, the voltage will repeat to the same value within about 1% indefinitely. For most applications, the inherent regulation from no load to full load is adequate.

A connection diagram will be found in the terminal box or on the connection diagram plate. Suitable overload protection should be provided, based on full load ampere rating shown on the name plate. Protect wiring circuits with proper size fuses selected according to local code requirements.

## **MAINTENANCE OF THE CONVERTER**

### Cleaning

It is most important that accumulations of oil, water, dirt, and dust are not permitted to cover the machine, enter it, or block ventilation. Remove any such accumulations from the machine and surrounding operating area.

Wipe the exterior of the machine to keep it clean. When necessary, use a suitable solvent to remove dirt accumulations from the machine surface.

Electrical machines should be protected from and kept free of acids, alkalines, chemical compounds and gas fumes that may cause insulation deterioration.

### Clean Windings

Accumulations of any foreign materials should be kept off the windings. Failure to keep the windings clean may result in short circuits, grounding of insulated surfaces, and in increased temperature rise.

The frequency of cleaning windings will have to be determined by operating conditions. However, it is a good policy to clean the windings at least once a year. Greasy or oily deposits may be wiped off with a lint free cloth dipped in suitable solvent. Take care not to leave solvent deposits on the windings. Light accumulations of nonconductive dust may be removed by compressed air. Use a pressure range of 40 to 60 psi. Do not blow directly into the windings. When dirt and dust accumulations are heavy or of a highly conductive nature, it is best to use an especially built vacuum cleaner to clean the machine. Follow the cleaner instructions carefully.

### Solvents

When the parts of a motor and generator need cleaning, use a suitable petroleum solvent such as

kerosene, petroleum spirits or Stoddard solvent. Care must be taken to utilize solvents in accordance with the solvent manufacturer's instructions. Protection in accordance with local laws regarding fire hazards must be provided. Gasoline containing lead compounds should not be used because of their toxic nature. Light petroleum solvents may be more effective but must be free of corrosive action and must be followed up with flushing oil.

## **BEARINGS**

Bearing life is estimated at more than 10,000 operating hours for normal operating conditions. Bearing replacement is required only when the bearings become noisy. This requires the disassembly of the unit.

## **CONVERTER DISASSEMBLY**

Disassemble converter for replacement of bearings. Use the following steps:

1. Remove 4 bolts, Item 2, from the top of the converter.
2. Remove 4 bolts, Item 5, from the motor flange.
3. Put a steel bar approximately 3/4" diameter through the eye bolts, and with a hoist slowly lift up motor housing, Item 7.
4. Screw into the end of the exposed shaft a 3/8-16 eye bolt and with a hoist slowly lift the shaft assembly, Item 1. The magnetic force will tend to hold the shaft assembly in place and it will be necessary to secure the generator housing, Item 1, to the work bench or floor.
5. Protect the generator rotor, Item 3, by wrapping it in heavy paper, and place it away from the iron or steel objects. If magnetic materials adhere to the rotor, this could cause partial demagnetization of the rotor. Iron and steel objects should be kept some distance from the rotor.

Removal of the shaft assembly will permit complete inspection of the generator and motor windings and removal of the bearings, Items 1, from the shaft assembly, using a proper size bearing puller. They should be removed in the same manner as when mounted; that is, from the shaft by force applied to the inner race only.

## **INSTALLATION OF THE BEARINGS**

The shaft bearing seat and bearing housing must be carefully cleaned to remove all traces of metal chips, filings, etc. To drive the inner ring of a bearing on a cylindrical shaft seat, a piece of tubing, squared on the ends should be used that will bear evenly against the face of the inner ring. Pressure should not be applied to the inner ring through the ball assembly by pushing against the outer ring. The bearing should be driven to a firm seat on the shaft shoulder.

Care must be taken that the bearing is started true and not cocked; otherwise, it is possible to roughen or burr the ground surface of the shaft. A light film of oil on the shaft and in the housing bore will prove an aid to mounting.

Do not force the bearing onto a shaft by blows applied to the outer race, nor into a housing by pounding upon the inner race.

To reassemble the converter reverse the order of the disassembly taking care not to damage the generator and motor windings. Clean any metal chips or particles from the rotors before installation. Check to see that the generator rotor turns freely and does not rub the stator. The generator leads should not be shorted when checking for a free turning rotor.

There should be a minimum air gap of at least 0.017 inches all around. This can be checked with a non-magnetic feeler gauge of the proper thickness and about 1/8 inch wide, through the inspection slots, located on the bottom of the generator housing. After inspection, be sure the inspection slots are closed with cover, Item 6.

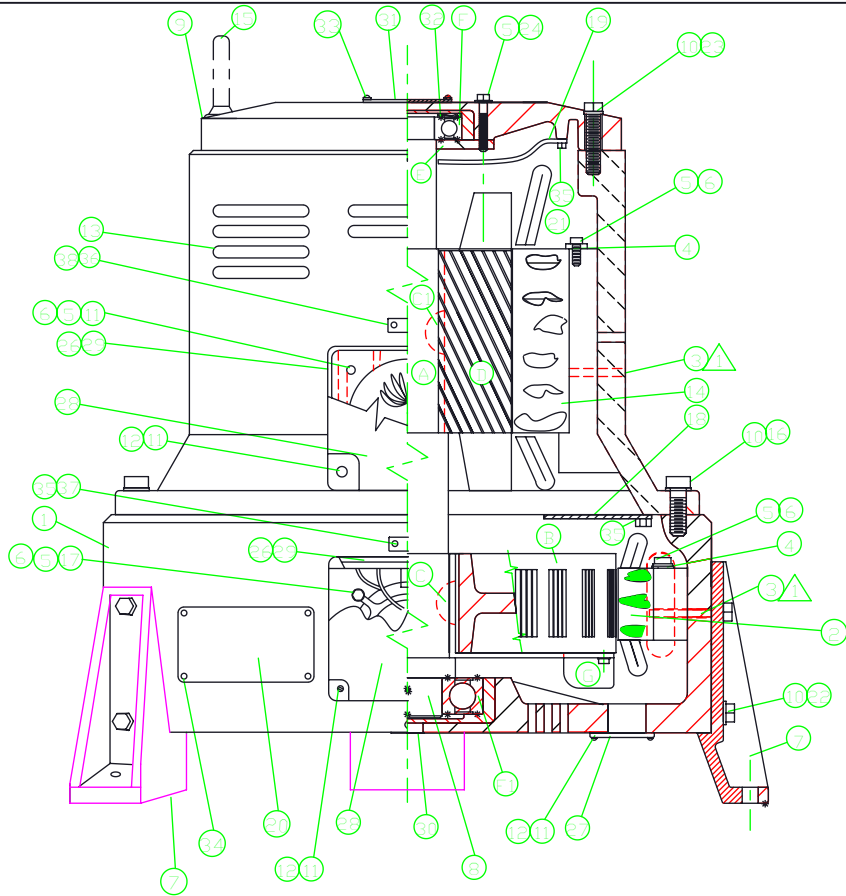

LIST OF MATERIAL			LIST OF MATERIAL		
ITEM	QTY	DESCRIPTION	ITEM	QTY	DESCRIPTION
1	1	Housing, Gen.	29	2	Gasket
2	1	Stator Assy. Gen.	30	1	Plug
3	2	Spiral Pin	31	1	Emblem
4	16	Retaining Washer	32	1	Spring Washer
5	28	Lockwasher	33	2	Screw
6	24	Bolt	34	4	Rivet
7	3	Feet	35	24	Screw
8	1	Shaft Assy.	36	1	Motor Connection Diag.
A	1	Shaft	*37	1	Output Connection Diag.
B	1	Rotor, Gen.	38	4	Rivet
C	1	Woodruff Key			
C1	1	Woodruff Key			
D	1	Rotor, Motor			
E	1	Cover, Bearing			
F	1	Bearing, Motor			
F1	1	Bearing, Gen.			
G	1	Fan			
9	1	End Bell			
10	17	Lockwasher			
11	20	Lockwasher			
12	20	Screw			
13	1	Housing, Motor			
14	1	Stator Assy. Motor			
15	2	Eye Bolt			
16	4	Bolt			
17	8	Flatwasher			
18	1	Baffle, Gen.			
19	1	Baffle, End Bell			
20	1	Nameplate			
21	1	Baffle, Motor			
22	9	Bolt			
23	4	Bolt			
24	4	Bolt			
26	2	Gasket			
27	4	Cover			
28	2	T. Box w/ Cover			

\*37 - 3 Ph. Output Only

NOTES:  
 1) 1/4"(.250) DRILL X .06 DP. INTO MOTOR & GEN. STATORS FOR (2)X ITEM 3.

UNSPECIFIED TOLERANCES		ASSEMBLY		Georator Corporation 9617 Center Street Manassas, VA 20110-5521, USA Telephone (703)-368-2101 FAX (703) 368-1078	
FRACTIONAL	±1/8	DIMENSIONS ARE IN INCHES			
DECIMAL		DO NOT SCALE		NAME	
2 PLACE	±0.030	DRAWING		ASSEMBLY DWG.	
3 PLACE	.010	DATE 12/20/01		FRAME 254T/20-A SER. VERT. CONV.	
SURFACE	±.010	DRAWN F.L.		MATERIAL	
PLOT @: FIT				PARTS LIST	
This drawing and any print thereof is the property of Georator Corporation and is subject to return on request by this company. The information herein is confidential and the recipient by accepting this drawing agrees not to use any information contained therein in any manner which will be detrimental to Georator Corporation.				DWG. NO.	
B	ADD 'C1' WOODRUFF KEY	2-17-04	M.H.	C 22-312	
A	Redrawn in Autocad, 33-006-5 was 33-006	12/06/01	B.D.	REV B	
REV.	DESCRIPTION	DATE	BY	SHEET 1 OF 1	

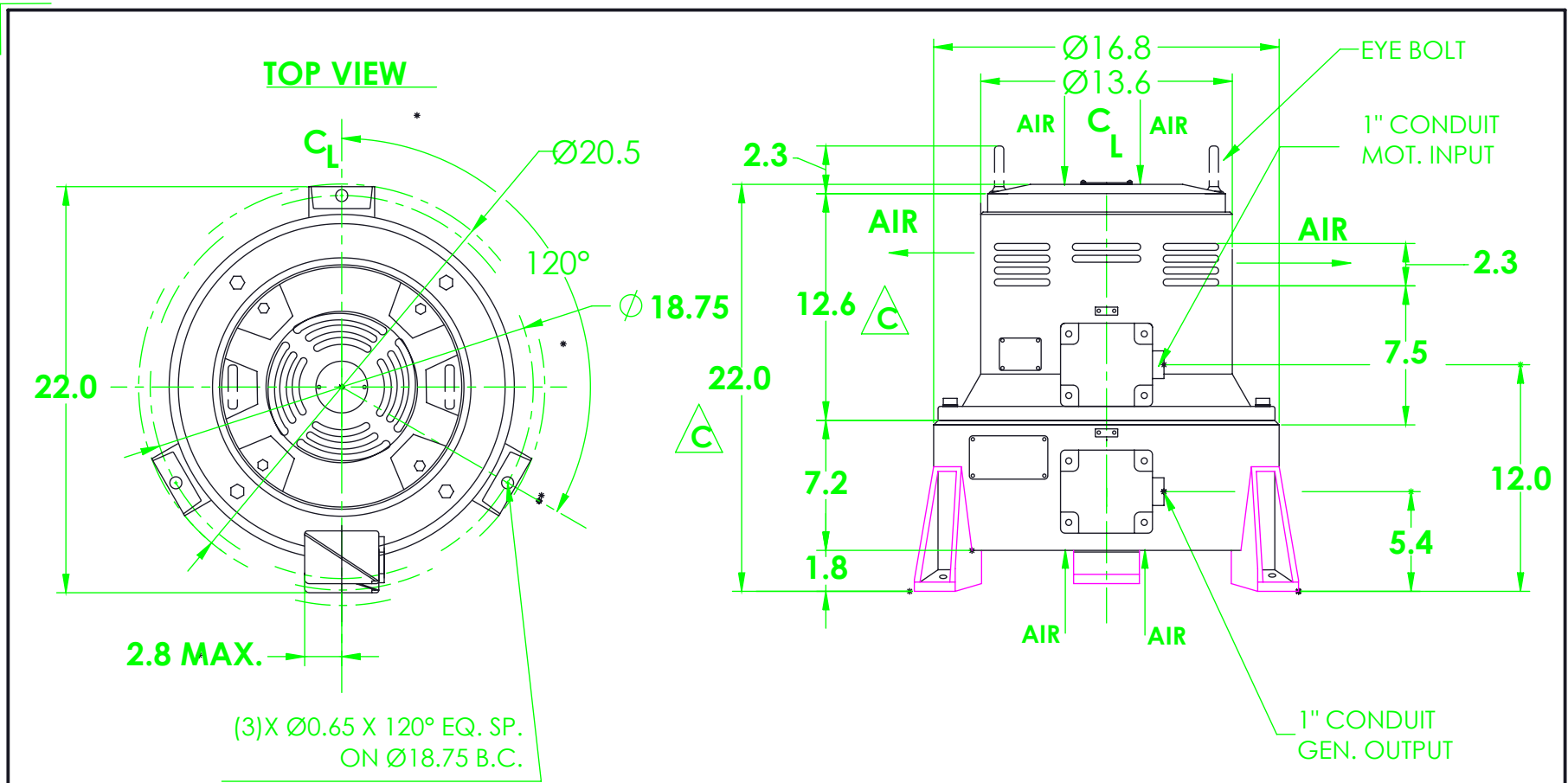

APPR. WEIGHT: 315 LBS.



REV.	DESCRIPTION	DATE	BY
C	22.0 WAS 19.5, 12.6 WAS 10.3	2-16-06	MH
B	315 WAS 280	11-18-05	MH
A	REDRAWN IN AUTOCAD	12/6/01	B.D.

UNSPECIFIED TOLERANCES FRACTIONAL ±1/8 DECIMAL ±0.030 2 PLACE ±0.030 3 PLACE N/A ANGULAR N/A	UNLESS OTHERWISE SPECIFIED DIMENSIONS ARE IN INCHES.
PLOT @: FIT	
This drawing and any print thereof is the property of Georator Corporation and is subject to return on request by this company. The information shown is confidential and the recipient by accepting this drawing agrees not to use any information contained thereon in any manner which will be detrimental to Georator Corporation.	

DO NOT SCALE DRAWING
DATE 12/14/71
DRAWN F.L.
FILE 23-686.DWG
APP'D.
SCALE NONE

<b>GEORATOR Corporation</b>	
9617 Center Street Manassas, VA 20110-5521, USA Telephone (703)-368-2101 FAX (703) 368-1078	
NAME	<b>OUTLINE DRAWING</b>
	<b>VERTICAL CONVERTER, SERIES 33, TYPE 22-A &amp; 21-A, 10-15 H.P. MOTOR</b>
MATERIAL	SEE BILL/LIST OF MATERIALS
FINISH	DWG. NO. <b>A 23-686</b>
SHEET 1 OF 1	REV <b>C</b>

INPUT

OUTPUT

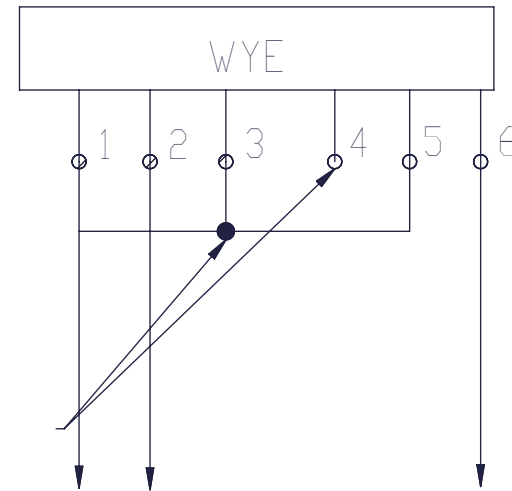
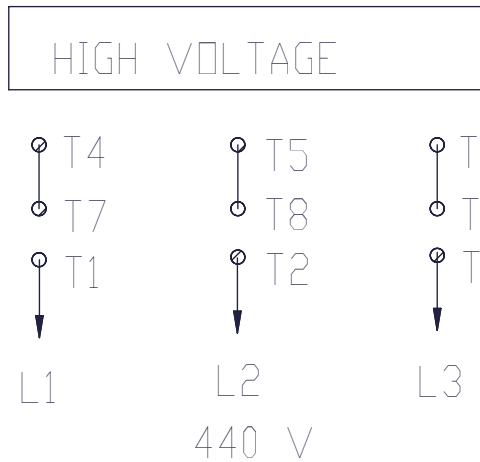
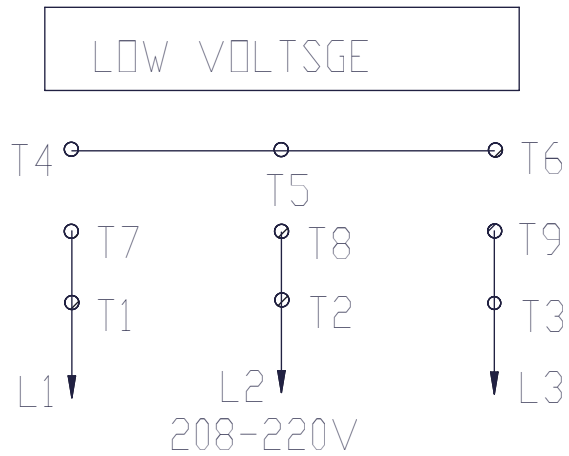

				UNSPECIFIED TOLERANCES: FRACTIONAL: 1/32 DECIMAL: 1 PLACE .05 2 PLACE .010 3 PLACE .005 ANGLES .010	UNLESS OTHERWISE SPECIFIED DIMENSIONS ARE IN INCHES.	 <b>GEORATOR Corporation</b> 7617 Center Street Manassas, VA 20108-5521, USA Telephone (703) 368-2101 FAX (703) 368-1078
				PLOT @: TO FIT	DO NOT SCALE DRAWING	
				This drawing and any print thereof is the property of Georator Corporation and is to return or request by this company. The information shown is confidential and the recipient by accepting this drawing agrees not to use any information contained therein in any manner which will be detrimental to Georator Corporation.	DATE: 1-11-08	INPUT: 3 PHASE OUTPUT: 1 PHASE
					DRAWN: F.M.	MATERIAL:
					FILE: 25-1119-1.DWG	
					APP'D:	FINISH: _____
					SCALE: NONE	DWG. NO: _____
REV.	DESCRIPTION	DATE	BY		SHEET 1 OF 1	REV.
						A 25-1119-1